

CITY LIVING



2 Chippendale Way Chippendale NSW

1 1 1

This stunning one-bedroom apartment is situated above the Central Park shopping center, which includes a Woolworths, Priceline Pharmacy & Anytime Fitness as well as being surrounded by an array of shops, cafe's, restaurants & amenities.

** Unfurnished**

KEY FEATURES

The Apartment - A one bedroom apartment with built-in wardrobes and a clever design for a tailor-made urban lifestyle. The apartment features a sleek stone kitchen with high quality Smeg gas appliances, with a combined living/dining area which opens to a sunlit balcony

Type : Apartment

View : <https://www.cityliving.com.au/lease/nsw/sydney-city/chippendale/residential/apartment/8097781>



Lewis Thompson
02 9299 0990

[For full version visit the website](https://www.cityliving.com.au)

<https://www.cityliving.com.au>

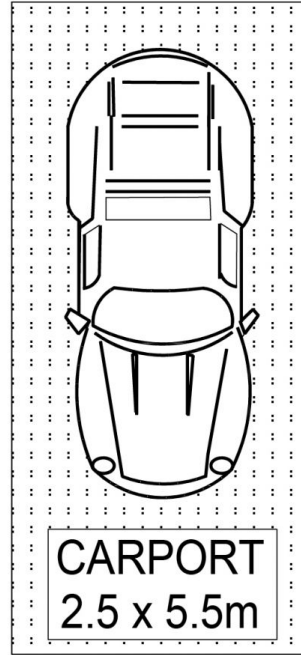
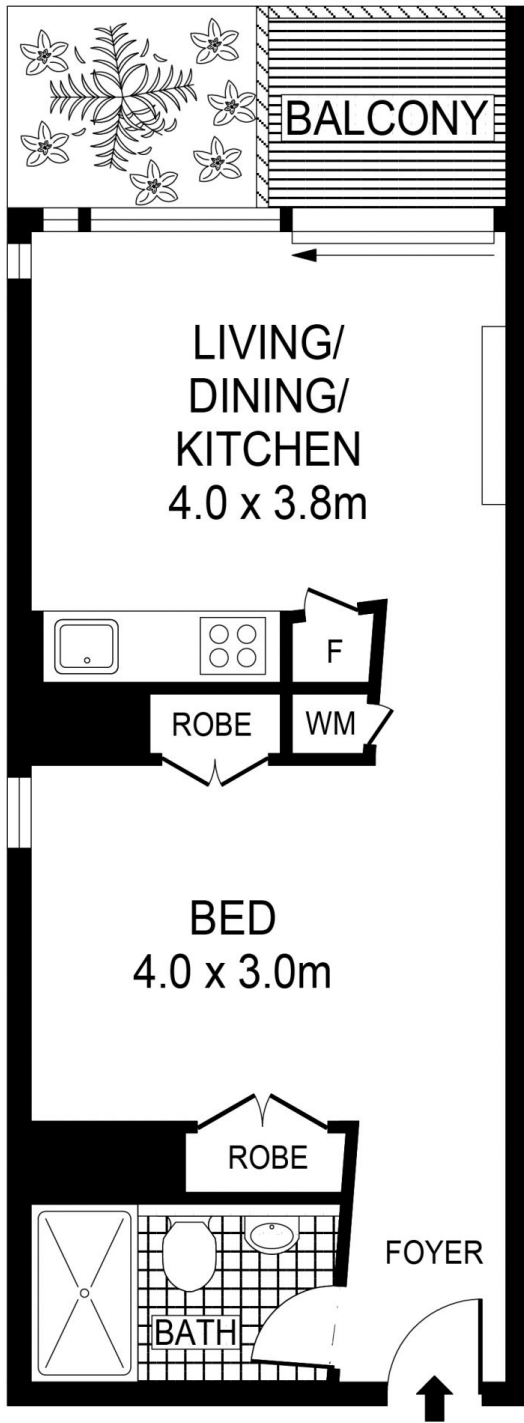

LEVEL FOURTEEN



PLANS SHOWN ONLY INDICATIVE OF LAYOUT. DIMENSIONS ARE APPROXIMATE.
Ref. No: 96422



1402/2 CHIPPENDALE WAY

CHIPPENDALE